

Honeywell

Reference Manual

MultiPro™ Gas Detector



Honeywell Analytics, Inc.
405 Barclay Blvd
Lincolnshire, IL 60069
(800) 711-6776 (847) 955-8200
Fax (800) 995-4992
27August 2012
P/N 13-278 Version 3

www.honeywellanalytics.com

WARNING

MULTIPRO PERSONAL PORTABLE GAS DETECTORS HAVE BEEN DESIGNED FOR THE DETECTION AND MEASUREMENT OF POTENTIALLY HAZARDOUS ATMOSPHERIC CONDITIONS

IN ORDER TO ASSURE THAT THE USER IS PROPERLY WARNED OF POTENTIALLY DANGEROUS ATMOSPHERIC CONDITIONS, IT IS ESSENTIAL THAT THE INSTRUCTIONS IN THIS REFERENCE MANUAL BE READ, FULLY UNDERSTOOD, AND FOLLOWED.

**MultiPro
Reference Manual
Part Number 13-278
Version 3
Copyright 2012
by
Honeywell Analytics, Inc.
Lincolnshire, Illinois 60069**

All rights reserved.

No page or part of this operation manual may be reproduced in any form without written permission of the copyright owner shown above.

Honeywell Analytics reserves the right to correct typographical errors.

Table of Contents

CERTIFICATION INFORMATION	5
OPERATING TEMPERATURE	5
SIGNAL WORDS	5
WARNINGS AND CAUTIONS	5
1. DESCRIPTION	8
1.1 Methods of sampling	8
1.2 Multi-sensor capability	8
1.3 Calibration	8
1.4 Alarm logic	9
1.4.1 Atmospheric hazard alarms	9
1.4.2 Low battery alarms	9
1.4.3 Sensor over range alarms.	9
1.4.4 LEL response failure due to lack of O2 alarm	9
1.4.5 Security beep/flash	10
1.4.6 Latching peak alarms	10
1.4.7 Fault detection	10
1.5 Other electronic safeguards	10
1.5.1 Heartbeat	10
1.6 Sensors	10
1.7 Optional sample draw pump	10
1.7.1 Special precautions when using the MultiPro pump	11
1.8 Data storage	11
1.8.1 Black box data recorder	11
1.8.2 Event logger	11
1.9 MultiPro design components	11
1.10 MultiPro standard accessories	12
1.10.1 Alkaline MultiPro detectors	12
1.10.2 Li-Ion MultiPro detectors	12
1.11 MultiPro kits	12
1.11.1 MultiPro Confined Space Kits	12
1.11.2 MultiPro Value Packs	12
2. BASIC OPERATIONS	12
2.1 Turning the MultiPro On	12
2.1.1 Start up with pump	14
2.2 Operating Logic	14
2.3 Turning the MultiPro Off	15
2.4 Alarms	15
2.4.1 Warning Alarms	15
2.4.2 Danger Alarms	15
2.4.3 STEL Alarms	15
2.4.4 TWA Alarms	15
2.4.5 Low battery alarms	15
2.4.6 Sensor over range alarms	16
2.4.7 LEL failure due to lack of oxygen alarm	16
2.5 PC connection via infrared port	16
2.6 Error Messages	17
2.7 Contact Cover	17
3. SAMPLING	17

3.1 Manual sample draw kit	17
3.1.1 Manual sample draw kit usage	17
3.2 Motorized sample draw pump	18
3.2.1 Starting the motorized sample pump	18
3.2.2 Turning off the pump	19
3.2.3 Pump low flow alarm	19
3.3 Sample draw probe	19
4. CALIBRATION	19
4.1 Functional (Bump) testing	20
4.2 Fresh Air/Zero Calibration	21
4.2.1 Fresh air/zero calibration failure	21
4.2.2 Forced fresh air / zero calibration	21
4.3 Span Calibration	22
4.3.1 Span calibration failure: Toxic and LEL sensors	22
4.3.2 Span calibration failure: Oxygen sensors	23
5. MAINTENANCE	23
5.1 Cleaning	23
5.2 Storage	23
5.3 Batteries	24
5.4 Replacing alkaline batteries	24
5.5 Maintaining Li-Ion battery packs	24
5.5.1 Storage guidelines for the Li-Ion versions	24
5.5.2 Charging guidelines for Li-Ion battery	25
5.5.3 Charging procedure for Li-Ion battery	25
5.5.4 Charging with the pump attached.	25
5.5.5 Battery troubleshooting	25
5.6 Sensor replacement	25
5.6.1 Sensor replacement (Not Duo-Tox)	25
5.7 Sample probe assembly	26
5.7.1 Changing sample probe filters	27
5.7.2 Changing sample probe tubes (wands)	27
5.8 MultiPro Pump Maintenance	27
5.8.1 Replacing pump filters	27
6. DIRECT PROGRAMMING	27
6.1 Entering the Advanced Menu	27
6.2 Set options	28
6.3 Set time	28
6.4 Set date	29
6.5 Set alarms	29
6.6 Set cal gas	29
6.7 Set cal due	29
6.8 Set bump test due	29
6.9 Setup accept	30
APPENDICES	31
Appendix A Toxic gas measurement – Warning, Danger, STEL and TWA alarms	31
1. Warning and Danger Alarms	31
2. Time Weighted Average (TWA):	31
3. Short Term Exposure Limits (STEL):	31
Appendix B Calibration Frequency Recommendation	33

Appendix C MultiPro Sensor Information	33
Appendix D Toxic Sensor Cross-Sensitivity	33
Appendix E Basic Parts List	33
MultiPro Remote Sampling Accessories	33
MultiPro Sensors	33
MultiPro Charging & Datalogging Accessories	33
Appendix F Honeywell Analytics Standard Gas Detection Warranty	35

Certification Information

UL Class I Division 1 Groups A,B,C,D Temp Code T4

UL Class II, Division 1 Groups E,F,G

UL Class III

CSA Class I, Division 1, Groups A,B,C,D Temp Code T4

(Per CSA C22.2 No. 152, only the combustible gas detection portion of this instrument has been assessed for performance)

ATEX Certification:

II 2 G Ex ia d IIC T4

UL International DEMKO A/S 05 ATEX 0424116X

IECEx Certification:

Ex ia d IIC T4

IECEx UL 07.0003X

Operating Temperature

⚠WARNING The MultiPro's operating temperature range is printed on the label on the back of the instrument. Use of Honeywell Analytics Gas Detectors outside of the instrument's specified operating temperature range may result in inaccurate and potentially dangerous readings.

Signal Words

The following signal words, as defined by ANSI Z535.4-1998, are used in the MultiPro Reference Manual.

⚠DANGER indicates an imminently hazardous situation which, if not avoided, will result in death or serious injury.

⚠WARNING indicates a potentially hazardous situation which, if not avoided, could result in death or serious injury.

⚠CAUTION indicates a potentially hazardous situation, which if not avoided, may result in moderate or minor injury.

CAUTION used without the safety alert symbol indicates a potentially hazardous situation which, if not avoided, may result in property damage.

Warnings and Cautions

1. **⚠WARNING** The MultiPro personal, portable gas detector has been designed for the detection of dangerous atmospheric conditions. An alarm condition indicates the presence of a potentially life-threatening hazard and should be taken very seriously.
2. **⚠WARNING** In the event of an alarm condition it is important to follow established procedures. The safest course of action is to immediately leave the affected area, and to return only after further testing determines that the area is once again safe for entry. Failure to immediately leave the area may result in serious injury or death.
3. **⚠WARNING** The MultiPro must be located in a non-hazardous location whenever alkaline batteries are removed from the alkaline battery pack. Removal of the alkaline batteries from the battery pack in a hazardous area may impair intrinsic safety.

4. **⚠️WARNING** Use only Duracell MN1500 or Ultra MX1500, Eveready Energizer E91-LR6, Eveready EN91 batteries in the alkaline battery pack. Substitution of batteries may impair intrinsic safety.
5. **⚠️WARNING** To reduce the risk of explosion, do not mix old or used batteries with new batteries and do not mix batteries from different manufacturers.
6. **⚠️WARNING** Do not charge the MultiPro with any charger other than the appropriate MultiPro charger. Standard versions of the MultiPro must be charged with the UL/CSA-approved charger, which is part number 54-49-103-1. European versions of the MultiPro must be charged with the ATEX-approved charger, which is Honeywell Analytics part number 54-49-103-5.
7. **⚠️WARNING** The MultiPro must be located in a non-hazardous location during the charging cycle. Charging the MultiPro in a hazardous location may impair intrinsic safety.
8. **⚠️WARNING** MultiPro rechargeable battery packs are supplied with Panasonic CGA103450 Lithium-Ion batteries. These batteries are not replaceable by the user. The rechargeable pack must be obtained from Honeywell Analytics and replaced as an assembly.
9. **⚠️WARNING** The accuracy of the MultiPro should be checked periodically with known concentration calibration gas. Failure to check accuracy can lead to inaccurate and potentially dangerous readings. (The Canadian Standards Association (CSA) requires an accuracy check using known concentration calibration gas prior to each day's use.)
10. **⚠️WARNING** Fresh air/zero calibrations may only be performed in an atmosphere that is known to contain 20.9% oxygen, 0.0% LEL and 0 PPM toxic gas.
11. **⚠️WARNING** The accuracy of the MultiPro should be checked immediately following any known exposure to contaminants by testing with known concentration test gas before further use. Failure to check accuracy can lead to inaccurate and potentially dangerous readings.
12. **⚠️WARNING** The accuracy of the MultiPro should be checked immediately following any physical shock. Failure to check accuracy can lead to inaccurate and potentially dangerous readings.
13. **⚠️WARNING** A sensor that cannot be calibrated or is found to be out of tolerance should be replaced immediately. An instrument that fails calibration may not be used until testing with known concentration test gas determines that accuracy has been restored, and the instrument is once again fit for use.
14. **⚠️WARNING** Do not reset the calibration gas concentration unless you are using a calibration gas concentration that differs from the one that is normally supplied by Honeywell Analytics for use in calibrating the MultiPro. Customers are strongly urged to use only calibration materials when calibrating the MultiPro. Use of non-standard calibration gas and/or calibration kit components can lead to dangerously inaccurate readings and may void the standard Honeywell Analytics warranty.
15. **⚠️WARNING** Use of non-standard calibration gas and/or calibration kit components when calibrating the MultiPro can lead to inaccurate and potentially dangerous readings and may void the standard Honeywell Analytics warranty. Honeywell Analytics offers calibration kits and long-lasting cylinders of test gas specifically developed for easy MultiPro calibration. Customers are strongly

urged to use only Honeywell Analytics calibration materials when calibrating the MultiPro.

16. **⚠️WARNING** Substitution of components may impair intrinsic safety.
17. **⚠️WARNING** For safety reasons this equipment must be operated and serviced by qualified personnel only. Read and understand this reference manual before operating or servicing the MultiPro.
18. **⚠️WARNING** A rapid up-scale reading followed by a declining or erratic reading may indicate a hazardous combustible gas concentration that exceeds the MultiPro's zero to 100 percent LEL detection range.
19. **⚠️WARNING** The MultiPro is not designed for use in oxygen enriched atmospheres.
20. **⚠️WARNING** Do not use the MultiPro pump for prolonged periods in an atmosphere containing a concentration of solvent or fuel that may be greater than 50% LEL.

1. Description

The MultiPro is a multi-sensor gas detector that can be configured to meet a wide variety of user requirements. This chapter provides an overview of many of the features of the MultiPro. More detailed descriptions of the specific features of the MultiPro are contained in the subsequent chapters of this manual.

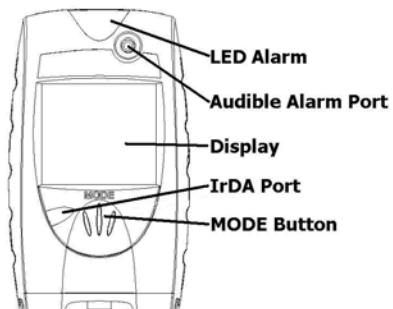

1.1 Methods of sampling

The MultiPro may be used in either diffusion or sample-draw mode. In either mode, the gas sample must reach the sensors for the instrument to register a gas reading. The sensors are located at the bottom of the instrument. There are three distinct sensor ports that allow the sample to reach the individual sensors.

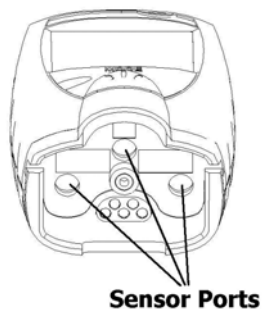

⚠️WARNING The sensor ports must be kept free of obstruction. Blocked sensor ports can lead to inaccurate and potentially dangerous readings.

In diffusion mode, the atmosphere being measured reaches the sensors by diffusing through the vents at the bottom of the instrument. Normal air movements are enough to carry the sample to the sensors. The sensors react quickly to changes in the concentrations of the gases being measured. Diffusion-style operation monitors only the atmosphere that immediately surrounds the detector.

The MultiPro can also be used to sample remote locations with the hand-aspirated sample-draw kit or with the motorized, continuous sample draw pump (both available separately). During remote sampling, the gas sample is drawn into the sensor compartment through the probe assembly and a length of tubing. Remote sampling operations only monitor the atmosphere at the end of the sample draw probe.

Use of the hand-aspirated sample draw kits is covered in section 3.1.

Use of the motorized sample draw pump is covered in section 3.2.

A detailed description of the MultiPro probe assembly is given in section 5.7.

1.2 Multi-sensor capability

The MultiPro can be configured to simultaneously monitor oxygen, carbon monoxide, hydrogen sulfide and combustible gases and vapors. All sensors are replaceable in the field. Each of the MultiPro's sensor channels is configured for a specific type of sensor.

Note: It is necessary to verify the accuracy of the MultiPro by calibration with known concentration test gas whenever a change is made to the sensors installed in the instrument.

Calibration procedures are discussed in detail in Chapter 4.

The MultiPro uses electrochemical toxic gas sensors that have been designed to minimize the effects of common interfering gases. These sensors provide accurate, dependable readings for toxic gases commonly encountered during confined space entry and other industrial applications.

Different measurement units are used depending on the gas being measured.

Type of Hazard	Measurement unit
Oxygen (O ₂)	Percentage by volume
Combustible gas	Percentage of lower explosive limit (%LEL)
Carbon Monoxide, Hydrogen Sulfide	Parts per million (PPM)

Table 1.2. Units of Measurement.

1.3 Calibration

The MultiPro detector features one-button fresh air and span calibration.

⚠️WARNING The accuracy of the MultiPro should be checked periodically with known concentration calibration gas. Failure to check accuracy can lead to inaccurate and potentially dangerous readings. (The Canadian Standards Association (CSA) requires an accuracy check using known concentration calibration gas prior to each day's use.)

Calibration procedures are discussed in detail in Chapter 4.

Recommended calibration frequency is discussed in Appendix B.

1.4 Alarm logic

MultiPro gas alarms can be adjusted with BioTrak Software through a PC with an IrDA port or directly with the MODE button (see Chapter 6 for direct programming instructions). Alarms may be set anywhere within the nominal range of the specific sensor type. When an alarm set point is exceeded a loud audible alarm sounds, and the bright red LED alarm lights flash.

1.4.1 Atmospheric hazard alarms

The combustible gas alarm is activated when the percent LEL (Lower Explosive Limit) gas concentration exceeds any pre-set alarm level.

Two oxygen alarm set points have been provided; a danger alarm for low concentrations associated with oxygen deficiency and a warning alarm for high concentrations associated with oxygen enrichment.

Four alarm set points have been provided for each toxic gas sensor: Warning, Danger, STEL (Short Term Exposure Limit) and TWA (Time Weighted Average).

S E N S O R	W A R N I N G	D A N G E R	S T E L	T W A
CO	35	100	100	35
H ₂ S	10	20	15	10

Default Toxic Sensor Alarm Levels

Appendix A discusses alarm levels and factory default alarm settings.

⚠WARNING MultiPro portable gas detectors have been designed for the detection of deficiencies of oxygen, accumulations of flammable gases and vapors, and accumulations of specific toxic gases. An alarm condition indicating the presence of one or more of these potentially life-threatening hazards should be taken very seriously.

⚠WARNING In the event of an alarm condition it is important to follow established procedures. The safest course

of action is to immediately leave the affected area, and to return only after further testing determines that the area is once again safe for entry. Failure to immediately leave the area may result in serious injury or death.

⚠WARNING A rapid up-scale reading followed by a declining or erratic reading may indicate a hazardous combustible gas concentration that exceeds the MultiPro's zero to 100 percent LEL detection range.

1.4.2 Low battery alarms

The MultiPro may be equipped with either a rechargeable Lithium Ion (Li-Ion) or an alkaline battery pack. The MultiPro includes multi-staged low battery alarms to let the user know that the battery is running low.

For detailed information concerning the low battery alarms, see section 2.4.5.

⚠WARNING Use only Duracell MN1500 or Ultra MX1500, Eveready Energizer E91-LR6, Eveready EN91 batteries. Substitution of batteries may impair intrinsic safety.

1.4.3 Sensor over range alarms.

The MultiPro will go into alarm if a sensor is exposed to a concentration of gas that exceeds its established range. In the case of an LEL reading that exceeds 100% LEL, the LEL channel will be automatically disabled by the instrument and the instrument will remain in constant alarm until it is turned off, brought to an area that is known to be safe, and then turned back on. The display will show "OL" in place of the sensor reading for any channel that has gone into over range alarm.

See section 2.4.5 for further details on sensor over range alarms.

A sensor range chart is provided in Appendix C.

⚠WARNING In the event of an LEL overrange alarm the MultiPro must be turned off, brought to an area that is known to be safe and then turned on again to reset the alarm.

1.4.4 LEL response failure due to lack of O₂ alarm

The MultiPro features automatic warning against LEL sensor response failure due to lack of oxygen. See section 2.4.7 for details.

1.4.5 Security beep/flash

The MultiPro includes a security beep function that is designed to notify the user that the instrument is powered up and running. Once enabled the MultiPro will emit a short audible beep and give a short flash on the LED at a user-defined interval. The security beep/flash function may be enabled and the interval may be changed with BioTrak software or directly with the MODE button (see Chapter 6 for direct programming instructions).

1.4.6 Latching peak alarms

The MultiPro's alarms are self-resetting unless the alarm latch is enabled. With the MultiPro's alarm latch enabled, the audible and visible alarms will continue to sound after the atmospheric hazard has cleared. Press the MODE button to reset the alarms. If the alarm latch is disabled and the alarm condition is no longer present, the instrument will automatically return to normal operation, and the visible and audible alarms cease without further input from the user.

1.4.7 Fault detection

MultiPro software includes a number of additional alarms designed to ensure the proper operation of the instrument. When the MultiPro detects that an electronic fault or failure condition has occurred, the proper audible and visible alarms are activated and an explanatory message or message code is displayed.

⚠WARNING The MultiPro is designed to detect potentially life threatening atmospheric conditions. Any alarm condition should be taken seriously. The safest course of action is to immediately leave the affected area, and return only after further testing determines that the area is once again safe for entry.

1.5 Other electronic safeguards

Each time the detector is turned on, the MultiPro automatically tests the LED alarm light, audible alarm, internal memory and pump status (if so equipped). The battery is monitored continuously for proper voltage. The MultiPro also monitors the connection of sensors that are currently installed. The detection of any electronic faults causes the activation of the audible and visible alarms and causes the display of the appropriate explanatory message.

1.5.1 Heartbeat

At the center of the display is a heart symbol that will blink every few seconds to show that the instrument is functioning normally.

1.6 Sensors

The MultiPro can be configured to simultaneously monitor oxygen, carbon monoxide, hydrogen sulfide and combustible gases and vapors. The sensor configuration of the MultiPro may be specified at the time of purchase, or changed in the field by appropriately trained personnel.

Note: A CF Value may be required when replacing the 54-49-24 CO/H₂S sensor. Instructions are included with the replacement sensor.

Replacement sensor part numbers and sensor ranges are given in Appendix B.

Sensor cross-sensitivity figures are given in Appendix C.

⚠WARNING A sensor that cannot be calibrated or is found to be out of tolerance must be replaced immediately. An instrument that fails calibration may not be used until testing with known concentration test gas determines that accuracy has been restored, and the instrument is once again fit for use.

Calibration procedures are discussed in detail in Chapter 4.

1.7 Optional sample draw pump

A motorized sample-draw pump is available for the MultiPro for situations requiring continuous "hands free" remote monitoring.

⚠WARNING Use only part number 54-49-102 sample draw pump with the UL/CSA-approved version of the MultiPro. Use only part number 54-49-102-5 sample draw pump with the ATEX-approved version of the MultiPro.

The pump contains a pressure sensor that detects restrictions in airflow caused by water or other obstructions being drawn into the unit and immediately acts to turn the pump off in order to protect the sensors, pump, and other MultiPro components from damage.

Pump status is continuously monitored by the MultiPro microprocessor. When the pump is

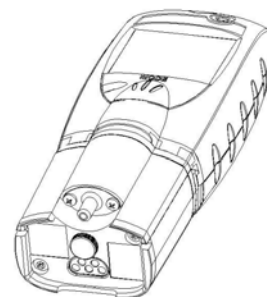

active and functioning properly, “PUMP” is displayed near the center of the display. Low flow or other pump fault conditions activate audible and visible alarms and cause the display of the appropriate explanatory message.

1.7.1 Special precautions when using the MultiPro pump

The rubber material used in the MultiPro diaphragm pump is susceptible to temporary compromise by exposure to high levels of flammable fuel and solvent vapors. If the MultiPro is being used to sample atmospheres that exceed 50% LEL, test the pump frequently to ensure that pump function has not been compromised.

To test the pump, block the end of the sampling line (probe) inlet with a finger. The pump should quickly go into alarm, which indicates proper function. If the pump fails to go into alarm while the inlet is blocked, it is not working properly; and the MultiPro may not be providing an accurate reading. If the pump test fails, the safest course of action is to immediately leave the affected area and to return only after further testing with known, functional detection equipment confirms that the area is once again safe for entry.

⚠WARNING Do not use the pump to sample for prolonged periods in conditions where the concentration of solvent or fuel vapors may be greater than 50% LEL.

1.8 Data storage

The MultiPro includes a black box data recorder and an event logger as standard features.

1.8.1 Black box data recorder

A black box data recorder is a standard feature in the MultiPro. The “black box” is continually in operation whether the user is aware of it or not. The black box stores important information such as gas readings, turn-on times, turn-off times, temperatures, battery conditions, the most recent calibration date and settings, types of sensors currently installed, sensor serial numbers, warranty expiration and service due dates, and current alarm settings.

There is a finite amount of memory storage available in the black box data recorder. Once the memory is “full”, the MultiPro will begin to write the new data over the oldest

data. The black box data recorder will store approximately 41 hours of data in one-minute increments before it begins to write new data over the oldest data. In this way, the newest data is always conserved.

To extract the information from the black box data recorder, the MultiPro must be returned to Honeywell Analytics. Once the data is downloaded from the instrument, a report will be generated. The instrument and the report will then be returned to the user. Simply call Honeywell Analytics Instrument Service Department to obtain a return authorization number. There is no charge for the downloading service, but the user is responsible for any freight charges incurred.

The “black box” data recorder in the MultiPro can be upgraded to a fully enabled datalogger at any time. All that is required is the activation code that corresponds to the serial number of the MultiPro.

1.8.2 Event logger

The event logger in the MultiPro stores data associated with alarm conditions. Each (alarm) event includes the following data for each of the installed sensors: Sensor type, Max reading, average reading, start time, end time and duration of the event. The MultiPro stores the 20 most recent events. Once 20 events have been stored, the MultiPro will begin to systematically overwrite the data from the oldest event in memory with data from new events. One event may be a combination of different alarms occurring simultaneously or in immediate succession. The event logger may be downloaded using Honeywell Analytics BioTrak software. The PC must be equipped with IrDA to provide a connection.

1.9 MultiPro design components

1. **Case:** The instrument is enclosed in a solid PC (polycarbonate) case with TPE (rubber) overmold.
2. **Front face:** The front face of the instrument houses the MODE button, LCD (liquid crystal display), LED alarm light, IrDA port and audible alarm.
3. **Display:** A liquid crystal display (LCD) shows readings, messages, and other information.
4. **Alarm light:** A top and front-mounted LED (light emitting diode) alarm lights provides a visual indication of alarm state. The light emits a bright red light when the instrument is in alarm.

5. **Infrared Port:** The infrared port is located next to the MODE button on the front face of the instrument. The infrared port is used for communications between the MultiPro and a PC.
6. **On / Off "MODE" button:** The large black push-button on the front of the instrument is called the "MODE" button. The MODE button is used to turn the MultiPro on and off as well as to control most other operations, including the automatic calibration adjustment.
7. **Sensor compartment cover:** The sensors are located in a vented compartment at the bottom of the instrument.
8. **Audible alarm port:** A cylindrical port extending through the front of the instrument just above the display houses the loud audible alarm. The waterproof audible alarm seats directly to the rubber inner-liner to protect the instrument against leakage or exposure to liquids.
9. **Battery pack:** Two types of interchangeable battery packs (rechargeable Lithium Ion (Li-Ion) and disposable alkaline) are available for use. Li-Ion battery packs may be recharged while the pack is installed in the instrument, or removed from the instrument for separate recharging.
10. **Battery charger connector:** A water-resistant connector at the bottom of the case assembly is used to connect the MultiPro to the "drop in" style charger.
11. **Back surface:** A sturdy clip allows the user to wear the MultiPro on a belt or other article of clothing.

1.10 MultiPro standard accessories

Standard accessories included with every MultiPro include calibration adapter, additional tubing for use during calibration, reference manual and quick reference card.

The optional manual sample draw kit consists of a sample draw / calibration adapter, squeeze bulb, standard sample probe, replacement sample probe filters, and ten feet of tubing. The sample probe itself is also available separately.

Standard configurations of the MultiPro are delivered in a cardboard box with cardboard inserts.

1.10.1 Alkaline MultiPro detectors

If the MultiPro has been purchased as an alkaline instrument, the standard accessories

include a set of 3 disposable AA alkaline batteries.

1.10.2 Li-Ion MultiPro detectors

If the MultiPro has been purchased as a Li-Ion rechargeable instrument, the standard accessories include Li-Ion battery pack and a slip-in MultiPro charger.

1.11 MultiPro kits

MultiPro detectors may also be purchased as part of a complete kit that includes calibration gas, fixed-flow regulator and a hard-shell carrying case.

1.11.1 MultiPro Confined Space Kits

In addition to the standard accessories listed above, Confined Space Kits also include calibration fittings, fixed-flow regulator with pressure gauge, and appropriate large cylinder of calibration gas in a foam-lined, waterproof hard-shell carrying case.

1.11.2 MultiPro Value Packs

MultiPro Value Packs include an alkaline MultiPro, all standard accessories, calibration fittings, small cylinder(s) of calibration gas, and fixed flow regulator in a foam-lined non-waterproof hard-shell carrying case.

2. Basic Operations

The MultiPro is a true one-button gas detector. The MODE button is located on the front of the instrument and controls all field-level operations including the following

- Turning the MultiPro on and off
- Turning on the backlight
- Viewing the MAX, STEL and TWA reading screens
- Initiating the calibration sequence

2.1 Turning the MultiPro On

To turn the MultiPro on, press and hold the MODE button for one second. The first screen shown will be the test screen for the LCD. All sections should be darkened. The test screen will be followed by a screen showing the instrument firmware version. "dL" will appear in the upper right for instruments with a fully enabled datalogger.



The sensor screen and instrument serial number screen will then be shown.

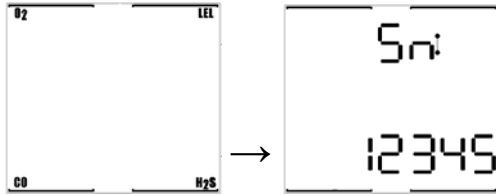

If the MultiPro is equipped with a fully enabled datalogger, the following screen will be shown. The time figure in the upper right corner indicates the sampling interval in minutes and seconds. Instruments without a fully enabled datalogger will show display “not a datalog”

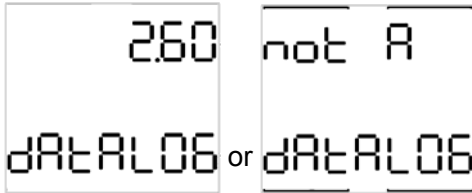

In the MultiPro, the standard one-minute sampling interval will result in the ability to store a minimum of 41 hours of readings before the oldest data is overwritten by new data. The sampling interval may be modified using BioTrak Software.

The time will then be shown followed by the date:



The instrument will display “Self Test” as it performs operational checks. During the self-test, the MultiPro tests for installed sensors, performs a system memory check and tests to see if a motorized pump is attached to the instrument. If a pump is detected, it will be briefly activated during the self-test. For details on start up procedures for MultiPro instruments equipped with a pump see section 2.1.1 below.

For instructions on changing the time and date with the MODE button, see section 6 below.

The instrument temperature will then be shown.

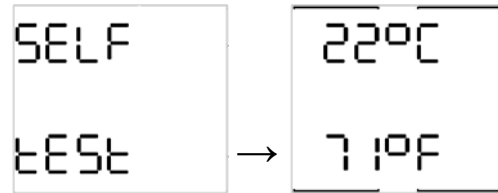

The warning alarm levels screen will then be shown followed by the danger, STEL and TWA alarm levels screens.

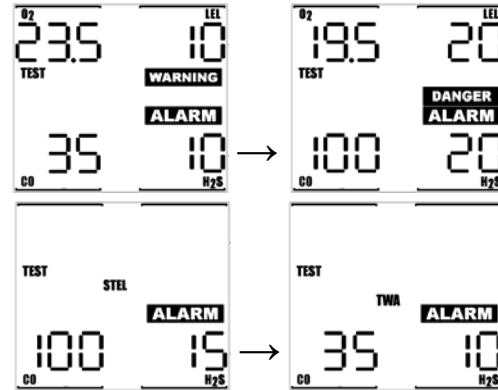

For more information concerning STEL and TWA alarms, see sections 2.4.3 and 2.4.4.

After the alarm screens, the calibration due screen will be shown with the number of days until the next calibration. The instrument will then proceed to the current gas readings screen. If calibration is due, “Cal due now” will be shown followed by “needs cal”. The user will need to acknowledge the message by pressing the MODE button. Once the MODE button is pressed, the MultiPro will continue to the current gas readings screen and the appropriate calibration due icon will blink every 5 seconds to remind the use that the instrument is past due for calibration.

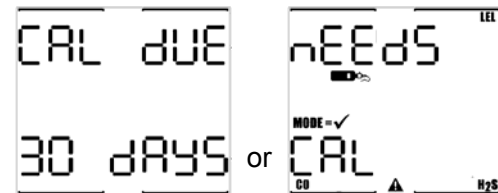

If the Bump Test Interval setting is enabled, the bump interval screen will be shown. The bump due status will be shown in days or hours.

Note: The Bump Test Interval and bump test due reminder are used exclusively with the MultiPro IQ Express Dock.

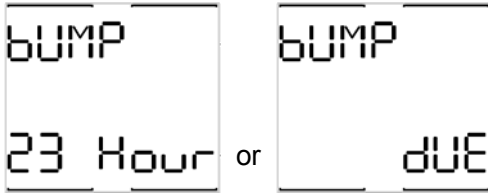

Following the calibration status screens, the MultiPro will proceed to the current gas readings screen.

2.1.1 Start up with pump

MultiPro instruments that are equipped with a built-in motorized sample draw pump will have a slightly longer start up sequence. After the calibration status screens, the MultiPro will prompt you to test the pump for leaks.

Note: The sample probe assembly must be attached when the pump is started.

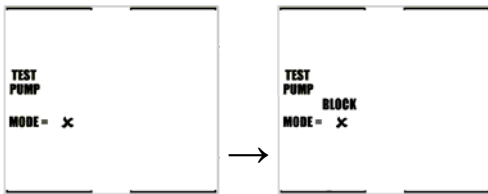

Block the sampling inlet by placing a finger over the end of the sample probe assembly. Once the MultiPro recognizes that the test is passed, it will instruct you to remove the blockage.

Once the blockage is removed, the MultiPro will proceed to the current gas readings screen.

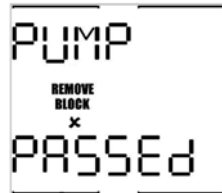

If the instrument is unable to detect the vacuum resulting from the pump blockage, the test will fail and you will be directed to remove the pump.

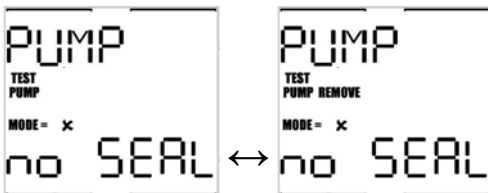

For information concerning proper attachment of the sample probe assembly to pump-equipped MultiPro instruments, see section 3.1.

2.2 Operating Logic

Once the MultiPro has completed the start up sequence, the current gas readings screen will be shown. At the center of the display is a heartbeat that

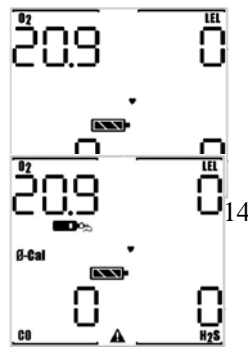

will “beat” every few seconds to show that the instrument is functioning normally.

If the MultiPro is due for fresh air/zero calibration, the “0-Cal” will flash on the LCD once every 5 seconds as a reminder. If the MultiPro is due for span calibration, the calibration bottle icon will be shown. Both “0-Cal” and the calibration bottle icon will be shown if the instrument is due for both span and fresh air calibration.



If a sensor is not detected in one of the sensor channels during start up, the reading in the designated sensor channel will appear blank. If a complete sensor failure occurs while the instrument is turned off, the instrument may operate as if the sensor is not present in the instrument. In the example at right, the LEL sensor has not been detected and a reading is not shown. The MultiPro™ only detects those substances that appear in the current gas readings screen during the current operating session.



⚠WARNING: Always verify that all sensors present in the instrument are shown on the current gas readings screen whenever the MultiPro™ is turned on. Failure to verify sensor presence prior to use in a hazardous location may result in serious injury or death.

If the MultiPro recognizes that the pump is attached, “Pump” will be displayed in the current gas readings screen

The battery icon gives an indication of how much power is left in the battery. The illustration below shows the stages of the battery from full to empty (top to bottom).

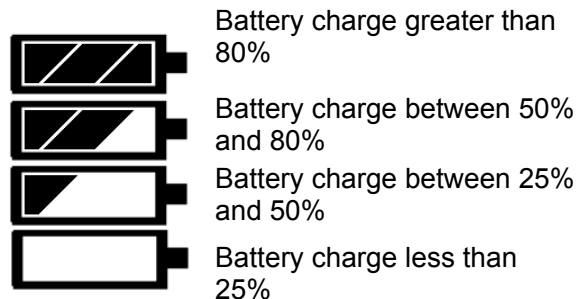

To turn on the backlight press the MODE button once. To view the MAX readings screen, press the MODE button a second

time. Press the MODE button a third time to view the Short Term Exposure Limit (STEL) readings. Press the MODE button again to view the Time Weighted Averages (TWA) for the operating session.

Note: The MultiPro must be in continuous operation for at least 15 minutes before it will be able to calculate the TWA values. For the first 15 minutes of any operating session, the screen will show the length of time that the instrument has been operating instead of the TWA values.

2.3 Turning the MultiPro Off

To turn the MultiPro off, press and hold the MODE button until the display reads “Release Button”. Once the MODE button is released “Please wait” will be shown briefly and the display will go blank.



2.4 Alarms

The MultiPro is configured with a series of alarms that are designed to warn the user of dangerous conditions.

⚠WARNING The MultiPro is designed to detect potentially life threatening atmospheric conditions. Any alarm condition should be taken seriously. The safest course of action is to immediately leave the affected area, and return only after further testing determines that the area is once again safe for entry.

2.4.1 Warning Alarms

A Warning Alarm indicates a dangerous atmospheric condition that has not yet risen to a level necessary to initiate the danger alarms. Warning alarm levels are shown during the start up sequence.



Warning alarms can be temporarily silenced by pressing the MODE button if this option is enabled with BioTrak.

2.4.2 Danger Alarms

A Danger Alarm indicates a significantly hazardous condition. As is the case with the warning alarms,



the danger alarm levels are shown in the start up sequence.

2.4.3 STEL Alarms

STEL (Short Term Exposure Limit) alarm values represent the average concentration of instrument readings for the target gas for the most recently completed 15 minutes of operation. The default STEL alarm level for the MultiPro CO sensor is 100PPM. The default STEL alarm value for the MultiPro H₂S sensor is 15PPM.



2.4.4 TWA Alarms

TWA (Time Weighted Average) values are calculated by taking the sum of exposure to a particular toxic gas in the current operating session in terms of parts-per-million-hours and dividing by an eight-hour period. The default TWA alarm level for the MultiPro CO sensor is 35PPM. The default TWA alarm value for the MultiPro H₂S sensor is 10PPM.

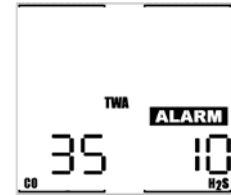

2.4.5 Low battery alarms

When battery voltage is reduced to approximately 3.55 volts, the battery icon on the LCD will appear empty, which means that a low battery condition exists.



If the battery icon is empty, leave the area immediately. If the MultiPro is equipped with an alkaline battery pack, proceed to an area that is known to be safe (containing fresh air with no contaminants and no combustible gases) and change the batteries. If the MultiPro is equipped with a Li-Ion battery pack, proceed to an area that is known to be safe and recharge the battery pack.

Once the battery voltage reaches 3.45 volts the MultiPro will go into a 30-minute battery alarm. The warning alarm will sound and the screen will display “Lo-Bat”, along with the warning and alarm icons. The user will need to acknowledge the low battery condition by pressing the MODE button before the instrument will resume monitoring. Once the MODE button is pressed, the empty battery cell and the caution icon will flash. After 15 minutes the warning will sound again to indicate that there are now only 15 minutes of battery life left. Once the second 15-minute

period has elapsed or once the battery voltage reaches 3.2 volts, the instrument will go into alarm for the last time, notify the user that it is shutting itself down and proceed to turn itself off.

Alkaline battery replacement and Li-Ion battery charging instructions are contained in section 5.4 and 5.5.

⚠WARNING The MultiPro must be located in a non-hazardous location during the charging cycle. Charging the MultiPro in a hazardous location may impair intrinsic safety.

⚠WARNING The MultiPro must be located in a non-hazardous location whenever alkaline batteries are removed from the alkaline battery pack. Removal of the alkaline batteries from the battery pack in a hazardous area may impair intrinsic safety.

CAUTION Always turn the MultiPro off prior to removing the battery pack. Removal of the battery pack with the instrument turned on may cause corruption of stored data in the MultiPro.

2.4.6 Sensor over range alarms

The MultiPro will go into alarm if a sensor is exposed to a concentration of gas that exceeds its established range. In the case of an LEL reading that exceeds 100% LEL, the LEL channel will be automatically disabled by the instrument and the alarm will latch (remain on) until the instrument is turned off. The MultiPro must be turned off, brought to an area that is known to be safe (containing 20.9% oxygen, 0% LEL and 0 PPM toxic gases), and then turned back on. The display will show “---” and “OL” alternately in place of the sensor reading for any channel that has gone into over range alarm.

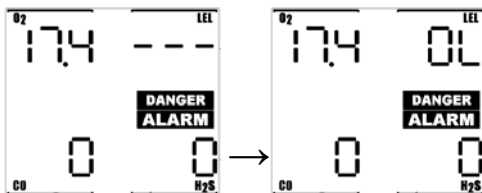

⚠WARNING A combustible sensor overrange alarm indicates a potentially explosive atmosphere. Failure to leave the area immediately may result in serious injury or death!

⚠WARNING In the event of an LEL overrange alarm the MultiPro must be

turned off, brought to an area that is known to be safe (containing 20.9% oxygen, 0% LEL and 0 PPM toxic gases), and then turned on again to reset the alarm.

2.4.7 LEL failure due to lack of oxygen alarm

The LEL sensor in the MultiPro requires a certain amount of oxygen to function properly. When oxygen levels fall below 11% by volume, the MultiPro will show “---” in place of the LEL reading and display “O2”, “too” and “Lo” in successive screens in the location typically used for the LEL reading.

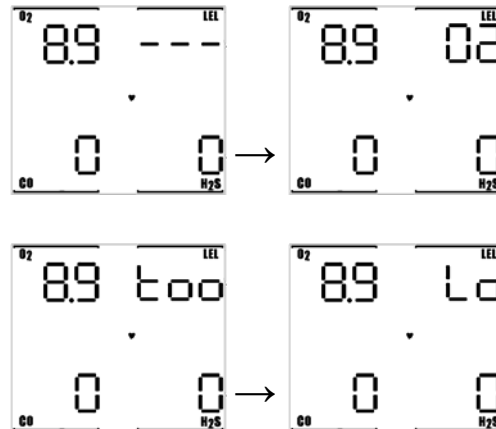

2.5 PC connection via infrared port

MultiPro instruments that are equipped with a fully enabled datalogger can be downloaded to a PC using BioTrak or IQ software through the MultiPro’s infrared port. For the location of the infrared port, see the illustration below.



1. With the MultiPro turned off, hold the MODE button down until four beeps are heard. Depending on the software version, this will normally take between 10 and 20 seconds. “PC Connect” will be shown once the infrared port has been activated.
2. Align the infrared port on the MultiPro with the PC’s infrared port to complete the connection.

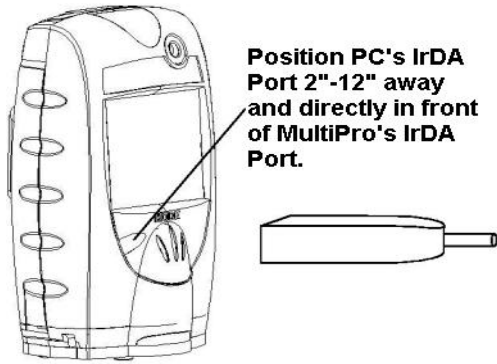

Position PC's IrDA Port 2"-12" away and directly in front of MultiPro's IrDA Port.

Note: For further instructions concerning the download procedure for the MultiPro, see the BioTrak or IQ System manual as appropriate.

2.6 Error Messages

The MultiPro will display error messages when it detects certain problems during operation.

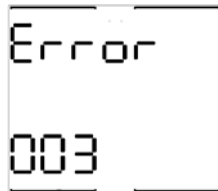

MULTIPRO Error definitions

Error	Display Number
Unit Memory Bad	003
O2 Memory Bad	004
LEL Memory Bad	005
CO Memory Bad	006
H2S Memory Bad	007
DataloggerMemory Bad	008
Invalid Memory Type	009
No Sensors Installed	010
Bad Temp Sensor	012
Bad Vibrating Alarm	014

If the MultiPro displays an error message, contact Honeywell Analytics for further instructions.

2.7 Contact Cover

ATEX and IECEx versions of the MultiPro are shipped with a clear red plastic contact cover that should be installed over the charging and pump contacts when the MultiPro is in use without the pump.

Note: This applies to European and Australian versions only. The contact cover is not required to meet the UL and CSA standards.

3. Sampling

The MultiPro may be used in either diffusion or sample-draw mode. In either mode, the gas sample must reach the sensors for the instrument to register a gas reading. The sensors are located at the bottom of the instrument.

⚠WARNING
The sensor ports must be kept free of obstruction. Blocked sensor ports can lead to inaccurate and potentially dangerous readings.

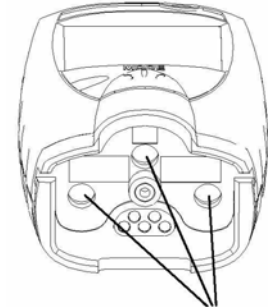

Sensor Ports

In diffusion mode, the atmosphere being measured reaches the sensors by diffusing through vents in the bottom of the instrument. Normal air movements are enough to carry the sample to the sensors. The sensors react quickly to changes in the concentrations of the gases being measured. Diffusion-style operation monitors only the atmosphere that immediately surrounds the detector.

The MultiPro can also be used to sample remote locations with either the hand-aspirated sample-draw kit, or with the motorized sample draw pump. During remote sampling, the gas sample is drawn into the sensor compartment through the probe assembly and a length of tubing.

3.1 Manual sample draw kit

The manual sample draw kit is comprised of a sample draw probe, 2 sections of tubing, a squeeze bulb and an adapter that is used to connect the sample draw accessories system to the MultiPro.

Note: The maximum amount of tubing that can be used with the manual sample draw kit is 50 feet.

3.1.1 Manual sample draw kit usage

To use the manual sample draw kit:

1. Connect the short section of hose that comes off the squeeze bulb to the sample draw adapter.
2. Test the seals in the sample draw system. First cover the end of the

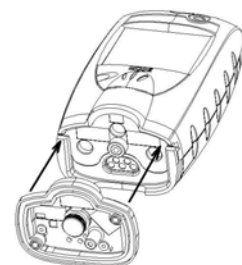

sample draw probe with a finger, then squeeze the aspirator bulb. If there are no leaks in the sample draw kit components, the bulb should stay deflated for a few seconds.

- Secure the calibration adapter (with the sample draw assembly attached) to the MultiPro by inserting the tab and tightening the knurled screw into the brass nut at the bottom of the adapter.
- Insert the end of the sample probe into the location to be sampled.
- Squeeze the aspirator bulb to draw the sample from the remote location to the sensor compartment.

To ensure accurate readings while using the manual sample draw kit, it is necessary to squeeze the bulb once for every one foot of sampling hose for the sample to first reach the sensors, and then to continue squeezing the bulb once per second for an additional 45 seconds or until readings stabilize. As an example, if 10 feet of tubing is used, it will be necessary to draw the sample in by squeezing the bulb continuously for a minimum of 55 seconds or until readings stabilize.

- Note the gas measurement readings.

CAUTION: Hand-aspirated remote sampling only provides continuous gas readings for the area in which the probe is located while the bulb is being continuously squeezed. Each time a reading is desired, it is necessary to squeeze the bulb a sufficient number of times to bring a fresh sample to the sensor compartment.

3.2 Motorized sample draw pump

⚠WARNING Use only part number 54-49-102 sample draw pump with the MultiPro.

A motorized sample-draw pump is available for the MultiPro for situations requiring continuous "hands free" remote monitoring. Use of the motorized sample draw pump allows the MultiPro to continuously monitor remote locations. The pump is powered by the MultiPro battery. When the pump is attached to the instrument, "PUMP" will be shown on the display in the current gas readings screen.

Note: The maximum amount of tubing that can be used with the motorized sample draw pump is 50 feet.

To ensure accurate readings while using the continuous sample pump, it is necessary to allow the pump to draw the sample for one second for every one foot of sampling hose plus an additional 45 seconds or until readings stabilize. For example, with 10' of tubing, it will be necessary to allow a minimum of 55 seconds for the sample to be drawn into the sensor chamber and for the readings to stabilize.

MultiPro instruments are designed to automatically recognize the pump whenever it is attached to the instrument. If the pump is attached when the MultiPro is turned off, the instrument will automatically initiate the pump start up sequence when the instrument is turned on. If the pump is attached while the instrument is running, the MultiPro will automatically initiate the pump test sequence before returning to the current gas readings screen.

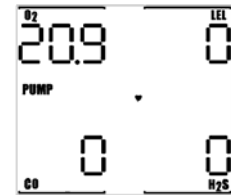

3.2.1 Starting the motorized sample pump

First attach the probe and tubing to the pump, then secure the pump (with the sample draw assembly attached) to the MultiPro by inserting the tab and tightening the knurled screw on the pump into the instrument casing.

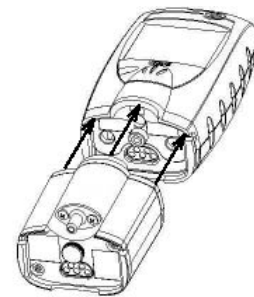

Note: The sample probe assembly must be attached to the pump when the pump is attached to the instrument.

Once the pump is recognized, the pump test sequence will be initiated automatically.

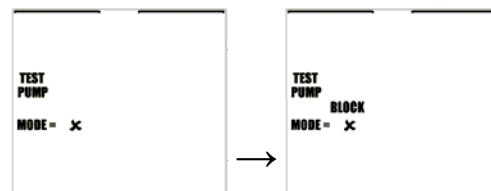

Block the sampling inlet by placing a finger over the end of the sample probe assembly.

Once the blockage is detected, the MultiPro will indicate that the test has been passed and instruct you to remove the blockage. Once the blockage is removed, it will proceed to the current gas readings screen.

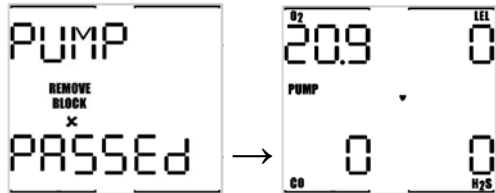

If the instrument is unable to detect the vacuum resulting from the pump blockage within 30 seconds, the test will fail, the instrument will go into alarm and you will be directed to remove the pump.

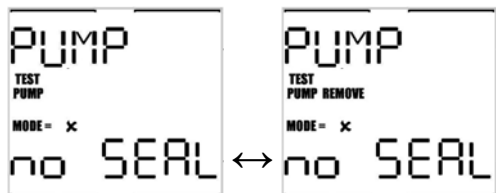

Remove the pump and press the MODE button to resume diffusion operation.

3.2.2 Turning off the pump

To turn off the pump, simply remove the pump from the instrument.

3.2.3 Pump low flow alarm

The MultiPro contains a pressure sensor that continuously monitors for restrictions in airflow caused by water or other fluids being drawn into the unit and immediately acts to turn the pump off in order to protect the sensors, pump, and other MultiPro components from damage.

CAUTION: Never perform remote sampling with the MultiPro without the sample probe assembly. The sample probe handle contains replaceable filters designed to block moisture and remove particulate contaminants. If the pump is operated without the probe assembly in place, contaminants may cause damage to the pump, sensors and internal components of the MultiPro

When the pump is active and functioning properly, "PUMP" is displayed near the center of the LCD display. Low flow or other pump fault conditions activate audible and visible alarms and cause the display of the appropriate explanatory message.

The pressure sensor in the sample draw pump is designed to detect pressure changes

while the sample-draw probe is being held in a vertical position. If the probe is held horizontally or at a low angle while inserted into a fluid, a pressure drop sufficient to cause the pump to shut down may not be generated, and water could be drawn into the pump assembly causing damage to the pump, sensors and internal components of the MultiPro.

CAUTION: Insertion of the sample draw tube into a fluid horizontally or at a low angle may lead to water ingress and may cause damage to the sensors and internal components of the MultiPro.

If the MultiPro determines that a significant pressure change has occurred, it will go into alarm and notify the user that there is a blockage of the pump. The display will alternate between the following two screens.

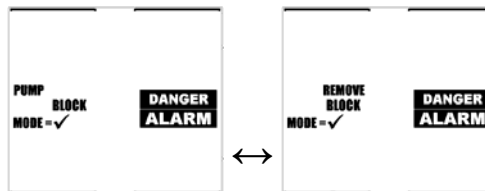

Remove the blockage and press the MODE button to acknowledge the alarm and resume sampling.

3.3 Sample draw probe

The MultiPro's sample draw probe is the standard probe assembly from Honeywell Analytics. The sample probe handle contains moisture barrier and particulate filters designed to remove contaminants that might otherwise harm the instrument.

Particulate contaminants are removed by means of a cellulose filter. The hydrophobic filter includes a Teflon™ barrier which blocks the flow of moisture as well as any remaining particulate contaminants.

Sample probe filters should be replaced whenever visibly discolored due to contamination.

See section 5.7.1 for a probe diagram and a list of available sample probe filter replacement kits.

4. Calibration

The accuracy of the MultiPro should be verified on a regular basis*. Verification can be as simple as performing a bump test, which is described below in section 4.1.

* **⚠WARNING** The Canadian Standards Association (CSA) requires the LEL sensor to be bump tested prior to each day's use with calibration gas containing between 25% and 50% LEL. The functional (bump) test procedure is covered in section 4.1.

If exposure to fresh air yields an oxygen reading of less than 20.7% or greater than 21.1% or a toxic or LEL sensor reading of anything other than 0, then a Fresh Air/Zero Calibration should be performed as described in section 4.2.

If exposure to a known concentration calibration gas (as described in section 4.1) shows that LEL or toxic sensor readings are not between 90%** and 120% of the value given on the calibration gas cylinder, then the Span Calibration should be performed as described in section 4.3.

** **⚠WARNING** The Canadian Standards Association (CSA) requires the instrument to undergo calibration when the displayed value during a bump test fails to fall between 100% and 120% of the expected value for the gas.

For Honeywell Analytics official recommendations concerning calibration frequency, see Appendix B.

4.1 Functional (Bump) testing

The accuracy of the MultiPro may be verified at any time by a simple functional (bump) test.

To perform a functional (bump) test, do the following:

1. Turn the MultiPro on and wait at least three minutes to allow the readings to fully stabilize. If any of the sensors have just been replaced, the new sensor(s) must be allowed to stabilize prior to use. See section 5.6 for further details on sensor stabilization requirements.
2. Make sure the instrument is located in fresh air.

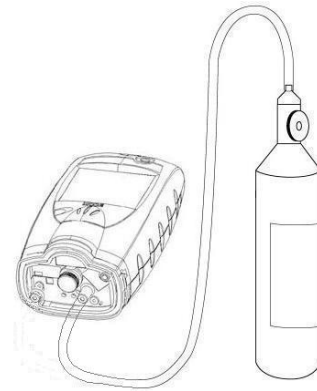

Figure 4.1 Bump Test / Span Calibration set up

3. Verify that the current gas readings match the concentrations present in fresh air. The oxygen (O₂) sensor should read 20.9% (+/-0.2% vol.). The readings for the LEL sensor should be 0% LEL and toxic sensors should read 0 or 0.0 parts-per-million (PPM) in fresh air. If the readings deviate from the expected levels in a fresh air environment, proceed to section 4.2 and perform the fresh air calibration adjustment then proceed to step 4.
4. Attach the calibration adapter and connect the calibration cylinder to the MultiPro as shown in figure 4.1. Flow gas to the sensors.
5. Wait for the readings to stabilize. (Forty-five seconds to one minute is usually sufficient.)
6. Note the readings. Toxic and LEL sensor readings are considered accurate in a bump test if they are between 90%* and 120% of the expected reading as given on the calibration cylinder. If the readings are considered accurate, then the instrument may be used without further adjustment. If toxic or LEL readings do not fall within 90%* and 120% of the expected reading as given on the calibration cylinder, then the readings are considered inaccurate. If readings are considered inaccurate, proceed to section 4.3 and perform the span calibration.

* **⚠WARNING** The Canadian Standards Association (CSA) requires the instrument to undergo calibration when the displayed value during a bump test fails to fall between 100% and 120% of the expected value for the gas.

Honeywell Analytics multi-calibration gas mixtures contain approximately 18%

oxygen. During the bump test the oxygen sensor should read within +/-0.5% (absolute) of the level given on the calibration cylinder.

4.2 Fresh Air/Zero Calibration

⚠WARNING Fresh air/zero calibrations may only be performed in an atmosphere that is known to contain 20.9% oxygen, 0% LEL and 0 PPM toxic gas.

To initiate the fresh air/zero calibration:

1. Press the MODE button three times within two seconds to begin the fresh air/zero calibration sequence. The MultiPro will briefly display AUTO CAL and then begin a 5-second countdown.



2. Press the MODE button before the end of the 5-second countdown to begin the fresh air/zero calibration. The fresh air/zero calibration has been initiated when the MultiPro alternates between the following two screens:

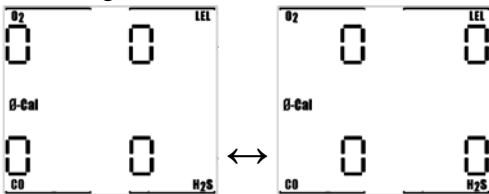

2. The fresh air/zero calibration is complete when the instrument begins another 5-second countdown for the span calibration. If span calibration is not required, allow the countdown to reach 0 without pressing the MODE button.

4.2.1 Fresh air/zero calibration failure

In the event of a fresh air/zero calibration failure, the alarms will be activated and the instrument will display the following screen. Note that the sensor(s) that fail the zero calibration are shown (in this case, CO)

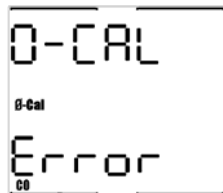

After 3 seconds, the MultiPro will return to the current gas readings screen and the visual and audible alarms will cease.



When fresh air/zero calibration is due, the MultiPro's display will show the warning symbol while intermittently displaying the 0-CAL icon in the gas readings screen until a successful fresh air calibration is performed. If a specific sensor has failed the fresh air/zero calibration, it will be displayed with the 0-Cal icon.

If a successful fresh air / zero calibration is not performed prior to instrument shut down, the MultiPro will show that Fresh Air Calibration is due during instrument start up.

Possible causes and solutions

1. The atmosphere in which the instrument is located is contaminated (or was contaminated at the time the instrument was last fresh air calibrated).
2. A new sensor has just been installed.
3. Instrument has been dropped or banged since last turned on.
4. There has been a significant change in temperature since the instrument was last used.

Recommended action:

Take the instrument to fresh air and allow readings to stabilize. Perform the fresh air/zero adjustment again. If the manual fresh air/zero procedure fails to correct the problem, perform the manual fresh air / zero calibration procedure as described in section 4.2.2 below.

4.2.2 Forced fresh air / zero calibration

The MultiPro includes safeguards to prevent fresh air calibration in contaminated environments. If the standard fresh air / zero calibration fails a second time, the instrument may be "forced" to accept the fresh air calibration by performing the manual fresh air / zero calibration.

⚠WARNING Fresh air/zero calibrations may only be performed in an atmosphere that is known to contain 20.9% oxygen, 0.0% LEL and 0 PPM toxic gas.

1. Initiate the standard fresh air / zero calibration sequence by pressing the MODE button three times in rapid succession. The 5-second countdown will begin.



2. Press the MODE button before the end of the 5-second countdown and **continue to hold the MODE button**. As in the

standard fresh air /zero calibration, the MultiPro will alternate between the following two screens:

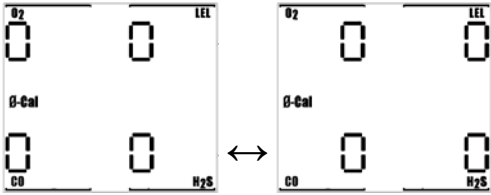

- The fresh air/zero calibration is complete when the instrument begins another 5-second countdown for the span calibration. If span calibration is not required, allow the countdown to reach 0 without pressing the MODE button.

If the MultiPro still fails to calibrate after attempting to force the fresh air / zero calibration, contact Honeywell Analytics.

4.3 Span Calibration

Once the fresh air / zero calibration has been successfully completed, the MultiPro will automatically proceed to the automatic span calibration countdown screen.

Press the MODE button before the countdown is complete to initiate the span calibration. The screen will immediately show “APPLY GAS” and then list the sensors for calibration and the expected levels of calibration gas.

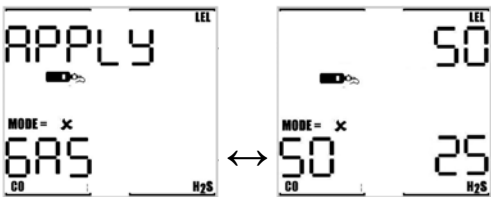

Note: Honeywell Analytics recommends the use of multi-component calibration gas for calibrating the MultiPro.

Apply calibration gas as shown above in figure 4.1. The readout will change to a numerical display almost immediately and will continue to display the current readings.

The actual calibration of the oxygen sensor to 20.9% occurs during the fresh air calibration, but the oxygen sensor is tested for response to diminished oxygen levels during span calibration. Honeywell Analytics calibration gas cylinders typically contain approximately 18.0% oxygen. In order to pass the span calibration, the instrument must register an oxygen reading below 19.5% during span calibration.

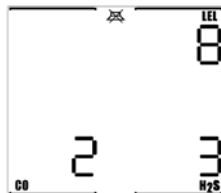

See section 4.3.2 below if the oxygen sensor does not detect the drop in oxygen level and fails the span calibration.

The calibration is fully automatic from this point on. Upon successful calibration of a sensor, the MultiVision will beep, show the adjusted reading for the calibrated sensor and then move on to the next sensor.

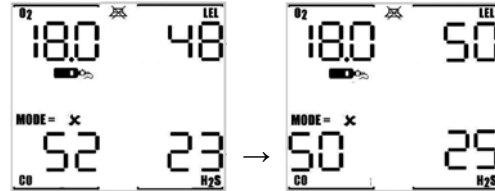

Once the calibration of all sensors is successfully completed, the MultiPro will briefly show the maximum adjustment values screen.

The maximum adjustment values for the LEL and toxic sensors give an indication of the remaining sensitivity of the sensors. As sensitivity decreases, the maximum possible adjustment will decrease to approach the expected concentration of the calibration gas.

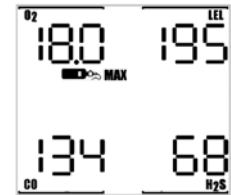

Note: Once the calibration cycle is completed, the MultiPro will automatically turn itself off. Disconnect the calibration assembly prior to turning the instrument back on.

4.3.1 Span calibration failure: Toxic and LEL sensors

When there is a span calibration failure, the display will show CAL Error and display the sensor that has failed calibration.

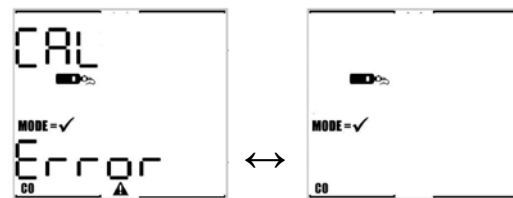

If the instrument fails to recognize the correct type or concentration of calibration gas, it will show “no GAS”.



When span calibration is due, the MultiPro’s display will show the warning symbol while intermittently displaying the calibration bottle in the gas readings screen.

The MultiPro will also display a “Needs Cal” message for any sensors that are currently due for calibration during instrument start-up.

Possible causes of span calibration failure and remedies:

1. Empty calibration gas cylinder. Verify that there is calibration gas in the cylinder.
2. Expired calibration gas cylinder. Verify that the expiration date on the cylinder has not passed.
3. Calibration gas setting does not correspond to calibration gas concentration. The default calibration gas settings are 50% LEL, 50PPM CO and 25PPM H₂S. If the values on the calibration cylinder are different from the instrument’s calibration gas settings, the MultiPro’s calibration gas settings must be changed to match the new values. Calibration gas values can be changed with the MultiPro programming software (available separately) or by accessing the setup menus with the MODE button as discussed in section 6.6 below.
4. LEL only: Type of calibration gas (standard) has changed significantly. LEL calibration gas may be based on several different response standards, methane, propane and pentane are the most common. If using a new cylinder of calibration gas, make sure that the type and amount of combustible gas is identical to that of the previous bottle. Honeywell Analytics offers calibration gases in Methane, Propane Equivalent and Pentane Equivalent.
5. Dead sensor. Replace sensor.
6. Instrument problem. Return the instrument to Honeywell Analytics. Call the phone number on the front of this manual.

4.3.2 Span calibration failure: Oxygen sensors

Honeywell Analytics multi calibration gas cylinders contain approximately 18.0% oxygen. The reduced oxygen level in the calibration gas cylinder allows the oxygen sensor’s response to be tested in the same manner as the toxic and LEL sensors.

If the O₂ sensor fails to register a reading below 19.5% during the span calibration, the display will show O2 Too Low followed by the O2 CAL Error screen



immediately after the failed calibration attempt.

Press MODE to acknowledge the warning and turn the instrument off.

If the oxygen sensor fails to register the drop in oxygen during the span calibration while being challenged with calibration gas containing less than 19.0% oxygen, it should be considered out of tolerance and retired from service immediately.

⚠WARNING A sensor that cannot be calibrated or is found to be out of tolerance should be replaced immediately. An instrument that fails calibration may not be used until testing with known concentration test gas determines that accuracy has been restored, and the instrument is once again fit for use.

Possible causes and remedies for oxygen sensor failure:

1. Calibration gas cylinder does not contain a reduced level of oxygen. Verify that the cylinder contains less than 19.0% oxygen. To challenge the oxygen sensor without calibration gas, hold your breath for about 10 seconds (or more), and then **slowly** exhale directly onto the face of the sensor (in the same way you would attempt to fog up a piece of glass). If the descending oxygen alarm is set to 19.5%, the instrument should go into alarm after a few seconds.
2. Oxygen sensor has just been replaced and has not had time to stabilize.
3. Oxygen sensor failure.

5. Maintenance

⚠WARNING To prevent ignition of flammable or combustible atmospheres, disconnect power before servicing any parts in the MultiPro.

5.1 Cleaning

The exterior surfaces of the MultiPro may be cleaned using a damp cloth only. Do not use cleaning agents of any kind. The introduction of cleaning agents to the detector may affect instrument functionality.

5.2 Storage

MultiPro detectors may be stored for long periods in a fresh air environment at temperatures between 10°C/50°F and 30°C/86°F.

See section 5.5.1 for specific instructions concerning the storage of rechargeable / Li-Ion versions of the MultiPro.

5.3 Batteries

The MultiPro is powered by interchangeable alkaline and Li-Ion rechargeable battery packs.

Note: The calibration adapter or sample draw adapter must be removed from the MultiPro prior to removing the battery pack.

To remove the battery pack first loosen the top center screw on the back of the instrument, then gently pry the two clasps at the top of the instrument open while simultaneously pulling the back cover plate away from the main instrument housing. Since the battery pack is housed in the back cover plate, this will automatically disconnect power from the instrument.

Loosen this screw, then gently pry the clasps apart

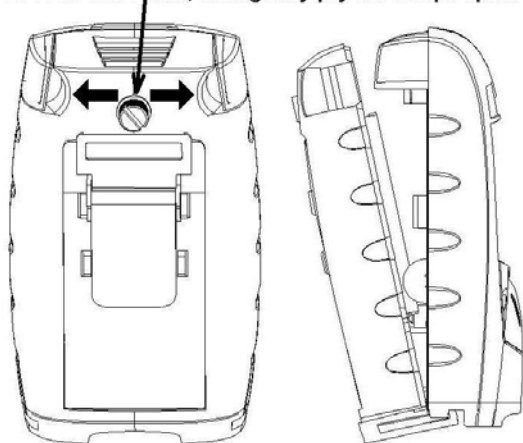

Note: Center screw on ATEX / European version is slightly different.

CAUTION Always turn the MultiPro off prior to removing the battery pack. Removal of the battery pack with the instrument turned on may cause corruption of stored data in the MultiPro.

5.4 Replacing alkaline batteries

The alkaline battery pack contains three AA alkaline batteries.

⚠WARNING The MultiPro must be located in a non-hazardous location whenever alkaline batteries are removed from the alkaline battery pack. Removal of the alkaline batteries from the battery pack in a hazardous area may impair intrinsic safety.

⚠WARNING Use only Duracell MN1500 or Ultra MX1500, Eveready Energizer E91-LR6, Eveready EN91 batteries. Substitution of batteries may impair intrinsic safety.

To replace the alkaline batteries:

1. Remove the battery pack from the MultiPro as discussed in above in section 5.3.
2. Remove the three alkaline batteries and replace them. Be sure to align the positive and negative ends in accordance with the diagram under each battery.
3. Reinstall the back cover plate that was removed in step 2.
4. Return the battery pack to the MultiPro and re-tighten the top center screw. The MultiPro will automatically turn itself on once the battery pack is reinstalled.

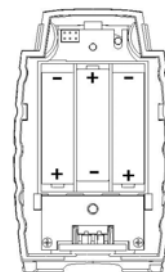

5.5 Maintaining Li-Ion battery packs

The MultiPro may be equipped with a rechargeable Li-Ion (Lithium Ion) battery pack.

5.5.1 Storage guidelines for the Li-Ion versions

Rechargeable batteries gradually lose their charge when not being used and may suffer irreversible damage if the battery reaches and remains in a state of complete discharge. Honeywell Analytics recommends fully charging the MultiPro Li-Ion battery at two-month intervals during storage to prevent damage to the battery. Rechargeable versions of MultiPro may also be stored for long periods of time on a powered MultiPro charger with no ill effects.

Storage of Li-Ion batteries at temperatures above 30C/86F may damage the internal components of the battery and lead to reduced battery capacity and voltage.

5.5.2 Charging guidelines for Li-Ion battery

The Li-Ion battery in the MultiPro should never be charged at temperatures lower than 5 degrees Celsius (40 degrees Fahrenheit) or higher than 30 degrees Celsius (86 degrees Fahrenheit). Charging at temperature extremes can permanently damage the MultiPro Li-Ion battery.

⚠WARNING The MultiPro must be located in a non-hazardous location during the charging cycle. Charging the MultiPro in a hazardous location may impair intrinsic safety.

5.5.3 Charging procedure for Li-Ion battery

⚠WARNING Do not charge the MultiPro with any charger other than the appropriate MultiPro charger. Standard versions of the MultiPro must be charged with the UL/CSA-approved charger, which is part number 54-49-103-1. European versions of the MultiPro must be charged with the ATEX-approved charger, which is part number 54-49-103-5.

1. Verify that the instrument is turned off. (If it is not, press the MODE button for three seconds until the message "Release Button" appears.)
2. Plug the power supply in. The red LED is labeled "Power" and will be lit whenever the charger is plugged into a power source.
3. Insert the MultiPro into the charging cradle bottom side down with the display facing forward. The green LED on the charger is labeled "Charge" and will be lit while the battery is charging.
4. When the battery is fully charged, the "Charge" LED will go out.

See section 5.5.5 for battery troubleshooting guidelines.

5.5.4 Charging with the pump attached.

To charge the MultiPro battery with the pump installed on the instrument, a spacer is used in the charger base to take up the difference between the size of the MultiPro and the size of the pump, which is slightly smaller. The spacer should be oriented with the gap towards the front of the



charger, and with the guide pins facing down towards the charger as shown in the illustration at right.

Once the spacer has been inserted, the MultiPro with pump may be charged according to the instruction given in section 5.5.3 above.

5.5.5 Battery troubleshooting

If the green "Charge" LED on the charger fails to light when the MultiPro with Li-Ion battery pack is placed in the charger, remove the instrument from the charger and press the MODE button to attempt to start the instrument.

If the battery has been inserted into the charger without the instrument, return it to the instrument prior to attempting the restart.

1. If the MultiPro starts and the battery icon shows all three bars, then the battery is fully charged and may be used. In this case, the charger has recognized that the battery is charged and will not charge it any further.
2. If the MultiPro fails to turn on, then the battery may be severely discharged and should be returned to the charger. The charger will then begin a very slow recharge in order to protect the battery. The green "Charge" LED may not be lit during the first four hours of the slow recharge. If the "Charge" LED has still not been lit after four hours, the battery pack or charger is probably damaged.
3. If the MultiPro starts and any battery level other than full is indicated, then either the battery is damaged or the charger is damaged. Call Honeywell Analytics for further instructions.

5.6 Sensor replacement

5.6.1 Sensor replacement (Not Duo-Tox)

Note: To replace the Duo-Tox (CO/H2S) sensor, follow the instructions that came with the new sensor.

The sensors in the MultiPro are located in a vented compartment at the bottom of the instrument.

To install a sensor:

1. Turn the MultiPro off.
2. Remove the battery pack as described in section 5.3. This will automatically disconnect power from the instrument.
3. Remove the four screws shown and pull the entire main board assembly free from the instrument housing.

- Gently remove the sensor that is to be replaced.

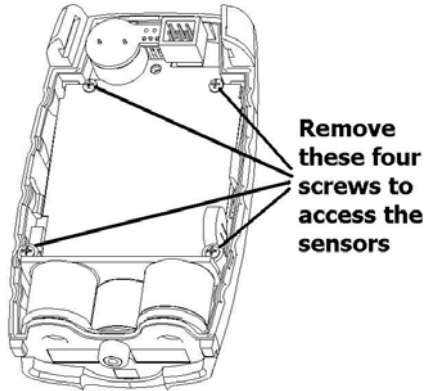

Remove these four screws to access the sensors

Note: Sensor channels in the MultiPro are specific to the type of sensor that occupies the channel. When replacing sensors, be sure to replace one sensor with another of the same type.

- Gently insert the new sensor into the appropriate location on the sensor board.
- Reinstall the main board assembly that was removed in step three and reinstall the four screws. The main board should easily slide back into place. The screw holes in the black mylar insulator should align with the corresponding holes in the housing. The sensor gaskets should be centered over the corresponding sensor ports at the bottom of the instrument, allowing the gas sample to reach the sensors. Be careful not to over tighten the screws.
- Reattach the battery pack and re-tighten the top center screw.
- New sensors must be allowed to stabilize prior to use according to the following schedule. The detector must be powered off and a functional battery pack must be installed for the sensor to stabilize.

Sensor	Stabilization Period
Oxygen (O ₂)	1 hour
LEL	none
CO	15 minutes
H ₂ S	15 minutes

Note: Steps 9 and 10 assume that the sensor stabilization period has passed.

- If an oxygen sensor was replaced, perform the Fresh Air/Zero calibration as discussed in section 4.2.
- If a combustible (LEL) or a toxic sensor has been replaced, perform both the Fresh Air/Zero calibration and the Span

calibration as discussed in sections 4.2 and 4.3.

5.7 Sample probe assembly

The MultiPro's sample draw probe is the standard probe assembly from Honeywell Analytics. The illustration below gives a breakdown of all parts in the sample draw probe with part numbers. The sample probe handle contains moisture barrier and particulate filters designed to remove contaminants that might otherwise harm the instrument.

Sample probe filters should be replaced whenever visibly discolored due to contamination.

CAUTION: Never perform remote sampling without the sample probe and hose assembly. The sample probe handle contains replaceable filters designed to block moisture and remove particulate contaminants. If the pump is operated without the probe assembly in place, contaminants may cause damage to the pump, sensors and internal components of the MultiPro.

Particulate contaminants are removed by means of a cellulose filter. The hydrophobic filter includes a Teflon™ barrier which blocks the flow of moisture as well as any remaining particulate contaminants.

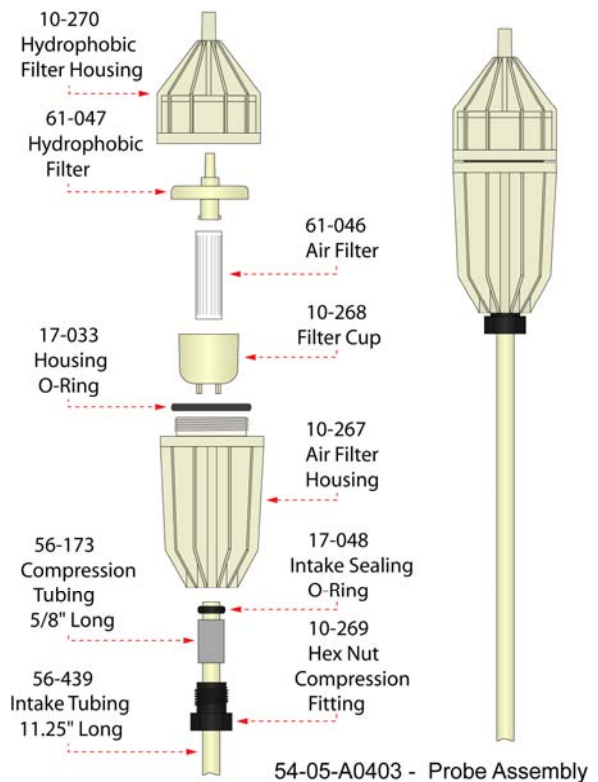

5.7.1 Changing sample probe filters

The threaded sample probe handle provides access to the filters. The particulate filter is held in place by a clear filter cup. To replace the particulate filter, remove the old filter and cup, insert a new filter into the cup, and slide the cup back into place in the probe handle. The hydrophobic barrier filter fits into a socket in the rear section of the probe handle. (The narrow end of the hydrophobic barrier filter is inserted towards the rear of the handle.)

To avoid accidentally introducing particulate contaminants into the system, turn the sample probe upside-down prior to removing either the hydrophobic filter or the particulate filter.

The following replacement filter kits are currently available from Honeywell Analytics:

Part No.	Kit	#Particulate	#Hydrophobic
54-05-K0401	Standard	10	3
54-05-K0402	Economy	10	0
54-05-K0403	Economy	30	10
54-05-K0404	Bulk	0	25
54-05-K0405	Bulk	100	0

5.7.2 Changing sample probe tubes (wands)

The standard 11.5" long butyrate probe tube is held in place with a hex-nut compression fitting and compression sleeve. The standard probe tube can be interchanged with other custom length sections of 1/4" OD tubing, or probe tubes made of other materials (such as stainless steel).

Probe tubes are exchanged by loosening the hex-nut compression fitting, removing the old tube, sliding the compression sleeve into place around the new tube, inserting the new tube into the probe handle, then replacing and tightening the hex-nut.

Note: The sample probe must be checked for leakage (as discussed in Section 3.1.1) whenever filters or probe tubes are exchanged or replaced before being returned to service.

5.8 MultiPro Pump Maintenance

MultiPro pumps are fairly maintenance free with the exception of the replacement of the pump filters on a regular basis.

5.8.1 Replacing pump filters

1. Remove the two screws that hold the inlet port to the pump.
2. Gently pull the dust filter holder free of the pump.

3. Remove and replace the dust filter that is located in the holder.



4. The hydrophobic filter is located beneath the inlet port in the pump housing. Use a small screwdriver or other object to punch through the filter and remove it. The gasket that sits between the inlet port and the filter should come out with the filter.
5. Place the new hydrophobic filter with the filter side down in place of the one removed in step 4. The gasket should be located on top of the filter and should sit against the dust filter holder, which will be reinstalled in step 6.
6. Replace the dust filter holder (which now has a new filter in it) and secure it with the two screws removed in step 1.

6. Direct programming

In the event that an instrument setting needs to be changed in the field and a PC with the appropriate software is not available, the MultiPro can be programmed directly with the MODE button.

⚠WARNING Reprogramming the MultiPro is reserved for authorized personnel. Inappropriate changes made in the Advanced Menu may lead to inaccurate and potentially dangerous readings.

6.1 Entering the Advanced Menu

To enter the "Advanced Mode", turn the MultiPro off. Then turn the MultiPro back on, but instead of releasing the MODE button, continue to hold it. The "PC Connect" screen will be shown in approximately 6 seconds. Continue to hold the MODE button for about 5 additional seconds until the "Config" screen is shown. Release the MODE button as soon as "Config" is shown.



The screen will show 6 sets of dashed lines.

Once the screen with the six dashed line is shown, immediately click the MODE button three times within three seconds to enter the Configuration Menu. "Setup" will be shown.



After a few seconds, the "Setup" screen will be replaced by the "Set Options" screen and will proceed to automatically scroll to a new screen every 5 seconds. The "Set Time" screen will follow the "Set Options" screen, which will then be followed by the "Set Date", "Set Alarms", "Set Cal Gas" and the "Set Cal Due" screens before returning to the "Set Options" screen.

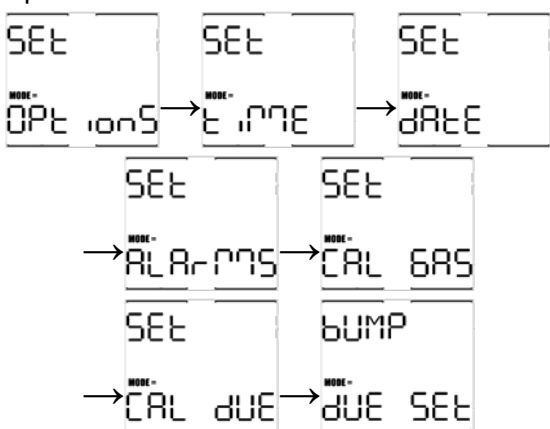

The MODE button is used to make all selections in the Advanced Menu.

1. Click the MODE button once to advance to the next menu screen
2. Click the MODE button three times in rapid succession to enter the submenu for the menu item that is currently shown.
3. Hold the MODE button for three full seconds to exit the advanced menu.

Once a submenu has been entered:

1. Click the MODE button once to advance to the next item in the submenu you've entered.
2. Hold the MODE button to modify the setting.
3. Click the MODE button three times in rapid succession to return to the Main Menu.

6.2 Set options

The set options submenu houses the controls for the following items:

- STEL (on or off)
- TWA (on or off)

- Security beep (on or off)
- Alarm Latch (on or off)
- Cal Due Use (on or off)
- Upload Cal (on or off)
- H₂S Decimal Point (on or off)

Once the Set options submenu is entered, the MultiPro will automatically scroll through the options at 5-second intervals. To change a setting for on to off (or vice-versa) hold the MODE button down for 1-2 seconds.

Once the settings have been modified as needed, click the MODE button three times in rapid succession to return to the Main Menu.

STEL and TWA Alarms are discussed in Appendix A.

The Security Beep is covered in section 1.4.5. Alarm Latch settings are described in section 1.4.6.

The Cal Due Use setting determines whether the instrument can be used when it is due for calibration. Selecting "Cal Due Use On" will allow the MultiPro to be used when it is due for calibration. Selecting "Cal Due Use Off" will cause the MultiPro to be shut down if the calibration is due and not performed immediately upon instrument turn on.

With the Upload Cal set to "on", the MultiPro will automatically enable the IrDA port and attempt to download the results of calibration to a PC immediately following the calibration. This is designed mostly for users of the IQ Datalink Program. In the default configuration, Upload Cal is set to "off", and the instrument will turn off following calibration.

Turn the H₂S decimal point on to view hydrogen sulfide readings in tenths of a part per million up to 9.9 PPM. Once the decimal point is enabled, a TWA alarm value option of 1.6 PPM will also appear under the alarm settings options.

6.3 Set time

When the set time option is accessed, the screen will alternate between the hours and minutes screens. The hours screen is given in 24-hour format. The two screens will alternate every 5 seconds.

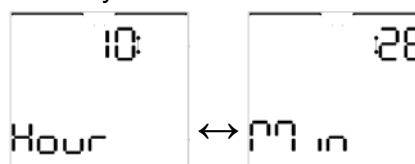

Click the MODE button once to change the selection from hours to minutes (or vice versa).

Hold the MODE button down to advance the figure that is currently displayed (hours or minutes).

Once the time has been correctly set, click the MODE button three times in rapid succession to return to the Main Menu.

6.4 Set date

The set date submenu is divided into year, month and day screens. The MultiPro will automatically scroll through the Year, Month and Day screens at 5-second intervals.

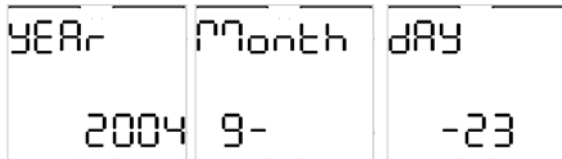

Click the MODE button once to advance through the year, month and day screens.

Hold the MODE button down to advance the year, month or day while the specific setting is shown.

Once the date has been correctly entered, click the MODE button three times in rapid succession to return to the Main Menu.

6.5 Set alarms

Once the "Set Alarms" submenu has been reached, the MultiPro will display the Default Alarms screen and then begin scrolling through the various alarm levels.



Click the MODE button once to advance through the screens.

When the alarm that you want to change is shown, hold the MODE button down to advance the counter until the appropriate level is shown. If the alarm level required is lower than the current setting, allow the counter to advance past the maximum possible alarm level for the specific channel, and continue back to the lower settings.

To restore the default alarms click the MODE button three times in rapid succession with "Default Alarms" displayed. "Def Set" will be shown to indicate that the default alarm settings have been restored.

Once the alarm values have been set correctly, click the MODE button three times rapidly to return to the Main Menu.

Note: To enable the H₂S TWA alarm setting of 1.6 PPM, first enable the H₂S decimal point as described above in section 6.2. The 1.6 PPM alarm value will then appear as an option in the TWA alarm setting for H₂S.

6.6 Set cal gas

Once the set cal gas submenu has been reached, the MultiPro will scroll through the various calibration gas values screens and the set default cal gas option.

Click the MODE button once to advance through the screens.

Hold the MODE button down to advance the counter for a specific calibration gas.

To set default calibration gas levels click the MODE button three times in rapid succession with "Default Cal Gas" displayed.

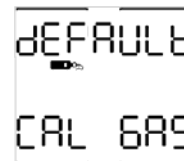

Once the calibration gas values have been set correctly, click the MODE button three times in rapid succession to return to the main menu.

6.7 Set cal due

Once the set cal due submenu is reached, the cal due screen will be shown.



Hold the MODE button down to advance the counter. The number of days shown is the number of days that must pass following a successful calibration before the calibration due warning will be shown. The maximum length of time between calibrations is 180 days.

To disable the calibration due warning, set the interval to 0 days (OFF).

Once the calibration due interval has been set correctly, click the MODE button three times rapidly to return to the Main Menu.

Note: Honeywell Analytics recommends regular verification of accuracy with calibration gas. See Appendix B for details.

6.8 Set bump test due

Once the bump due submenu is reached, the bump due screen will be shown. The number of days shown is the number of days that must pass following a successful calibration before the bump due warning will be shown.

Hold the MODE button down to advance the counter in days. OFF will be followed by DAILY, which will then be followed by 2 days and so on. Once the interval passes 7 days, it

will proceed to 14 days and then to 21 days and then to 30 days before it shows OFF again. The maximum length of time between scheduled bump tests is 30 days.

To disable the bump due warning, set the interval to OFF.

Once the bump due interval has been set correctly, click the MODE button three times in rapid succession to return to the Main Menu.



Note: The Bump Test Interval and Bump Test Reminder are used exclusively with the MultiPro IQ Express Dock.

6.9 Setup accept

Once the settings in any of the submenus have been changed as needed, return to the Main Menu by clicking the MODE button three times in rapid succession. Once in the Main Menu hold the MODE button down for three seconds to exit. The MultiPro will provide a countdown to accept changes to the settings.

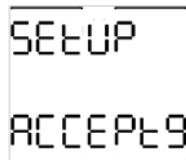

Click MODE to accept the changes and the instrument will show "setup stored" and proceed to turn itself off. Allow the countdown to run out if you do not wish to save the changes.

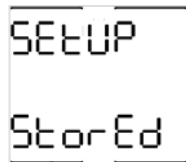

Appendices

Appendix A Toxic gas measurement – Warning, Danger, STEL and TWA alarms

Many toxic substances are commonly encountered in industry. The presence of toxic substances may be due to materials being stored or used, the work being performed, or may be generated by natural processes. Exposure to toxic substances can produce disease, bodily injury, or death in unprotected workers.

It is important to determine the amounts of any toxic materials potentially present in the workplace. The amounts of toxic materials potentially present will affect the procedures and personal protective equipment that must be used. The safest course of action is to eliminate or permanently control hazards through engineering, workplace controls, ventilation, or other safety procedures. Unprotected workers may not be exposed to levels of toxic contaminants that exceed Permissible Exposure Limit (PEL) concentrations. Ongoing monitoring is necessary to insure that exposure levels have not changed in a way that requires the use of different or more rigorous procedures or equipment.

Airborne toxic substances are typically classified on the basis of their ability to produce physiological effects on exposed workers. Toxic substances tend to produce symptoms in two time frames.

Higher levels of exposure tend to produce immediate (acute) effects, while lower levels of long-term (chronic) exposure may not produce physiological symptoms for years.

Hydrogen sulfide (H₂S) is a good example of an acutely toxic substance which is immediately lethal at relatively low concentrations. Exposure to a 1,000 ppm (parts per million) concentration of H₂S in air produces rapid paralysis of the respiratory system, cardiac arrest, and death within minutes.

Carbon monoxide (CO) is a good example of a chronically toxic gas. Carbon monoxide bonds to the hemoglobin molecules in red blood cells. Red blood cells contaminated with CO are unable to transport oxygen. Although very high concentrations of carbon monoxide may be acutely toxic, and lead to immediate respiratory arrest or death, it is the long term physiological effects due to chronic exposure at lower levels that take the greatest toll of affected workers. This is the situation with regards to smokers, parking garage attendants, or others chronically exposed to carbon monoxide in the workplace. Exposure levels are too low to produce immediate symptoms, but small repeated doses reduce the oxygen carrying capacity of the blood over time to dangerously low levels. This partial impairment of the blood supply may lead over time to serious physiological consequences.

Because prudent monitoring programs must take both time frames into account, there are two independent exposure measurements and alarm types built into the MultiPro design.

1. Warning and Danger Alarms

OSHA has assigned some, but not all, toxic substances with a ceiling level which represents the highest concentration of a toxic substance to which an unprotected worker should ever be exposed, even for a very short time. The default Warning and Danger alarm levels in the MultiPro are less than or equal to the OSHA-assigned ceiling levels for both CO and H₂S. **Never enter an environment even momentarily when concentrations of toxic substances exceed the level of either the Warning or the Danger Alarm.**

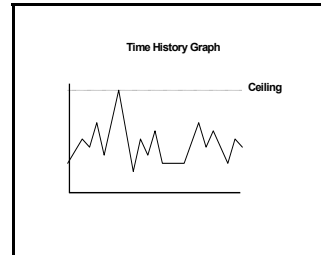

2. Time Weighted Average (TWA):

The maximum average concentration to which an unprotected worker may be exposed over an eight hour working day is called the Time Weighted Average or TWA value. TWA values are calculated by taking the sum of exposure to a particular toxic gas in the current operating session in terms of parts-per-million-hours and dividing by an eight-hour period.

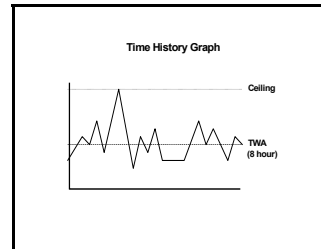

3. Short Term Exposure Limits (STEL):

Toxic substances may have short term exposure limits which are higher than the eight hour TWA. The STEL is the maximum average concentration to which an unprotected worker may be exposed in any fifteen minute interval during the day. During this time, neither the eight hour TWA or the ceiling concentration may be exceeded.

Any fifteen minute periods in which the average STEL concentration exceeds the permissible eight hour TWA must be separated from each other by at least one hour. A maximum of four of these periods are allowed per eight hour shift.

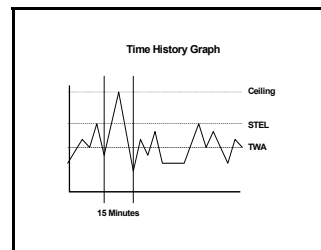

Appendix B Calibration Frequency Recommendation

One of the most common questions that we are asked at Honeywell Analytics is: ***“How often should I calibrate my gas detector?”***

Sensor Reliability and Accuracy

Today’s sensors are designed to provide years of reliable service. In fact, many sensors are designed so that with normal use they will only lose 5% of their sensitivity per year or 10% over a two-year period. Given this, it should be possible to use a sensor for up to two full years without any significant loss of sensitivity.

Verification of Accuracy

With so many reasons why a sensor can lose sensitivity and given the fact that dependable sensors can be key to survival in a hazardous environment, frequent verification of sensor performance is paramount.

There is only one sure way to verify that a sensor can respond to the gas for which it is designed. That is to expose it to a known concentration of target gas and compare the reading with the concentration of the gas. This is referred to as a “bump” test. This test is very simple and takes only a few seconds to accomplish. **The safest course of action is to do a “bump” test prior to each day’s use***. It is not necessary to make a calibration adjustment if the readings fall between 90%** and 120% of the expected value. As an example, if a CO sensor is checked using a gas concentration of 50 PPM it is not necessary to perform a calibration unless the readings are either below 45 PPM or above 60 PPM.

*** The Canadian Standards Association (CSA) requires the LEL sensor to be bump tested prior to each day’s use with calibration gas containing between 25% and 50% LEL.**

**** The Canadian Standards Association (CSA) requires the instrument to undergo calibration when the displayed value during a bump test fails to fall between 100% and 120% of the expected value for the gas.**

Lengthening the Intervals between Verification of Accuracy

We are often asked whether there are any circumstances in which the period between accuracy checks may be lengthened.

Honeywell Analytics is not the only manufacturer to be asked this question! One of the professional organizations to which Honeywell Analytics belongs is the Industrial Safety Equipment Association (ISEA). The “Instrument Products” group of this organization has been very active in developing a protocol to clarify the minimum conditions under which the interval between accuracy checks may be lengthened.

A number of leading gas detection equipment manufacturers have participated in the development of the ISEA guidelines concerning calibration frequency. Honeywell Analytics procedures closely follow these guidelines.

If your operating procedures do not permit daily checking of the sensors, Honeywell Analytics recommends the following procedure to establish a safe and prudent accuracy check schedule for your Honeywell Analytics instruments:

1. During a period of initial use of at least 10 days in the intended atmosphere, check the sensor response daily to be sure there is nothing in the atmosphere that is poisoning the sensor(s). The period of initial use must be of sufficient duration to ensure that the sensors are exposed to all conditions that might have an adverse effect on the sensors.
2. If these tests demonstrate that it is not necessary to make adjustments, the time between checks may be lengthened. The interval between accuracy checking should not exceed 30 days.
3. When the interval has been extended the toxic and combustible gas sensors should be replaced immediately upon warranty expiration. This will minimize the risk of failure during the interval between sensor checks.
4. The history of the instrument response between verifications should be kept. Any conditions, incidents, experiences, or exposure to contaminants that might have an adverse effect on the calibration state of the sensors should trigger immediate re-verification of accuracy before further use.
5. Any changes in the environment in which the instrument is being used, or changes in the work that is being performed, should trigger a resumption of daily checking.
6. If there is any doubt at any time as to the accuracy of the sensors, verify the accuracy of the sensors by exposing them to known concentration test gas before further use.

Gas detectors used for the detection of oxygen deficiencies, flammable gases and vapors, or toxic contaminants must be maintained and operated properly to do the job they were designed to do. Always follow the guidelines provided by the manufacturer for any gas detection equipment you use!

If there is any doubt regarding your gas detector's accuracy, do an accuracy check! All it takes is a few moments to verify whether or not your instruments are safe to use.

One Button Auto Calibration

While it is only necessary to do a “bump” test to ensure that the sensors are working properly, all current Honeywell Analytics gas detectors offer a one button auto calibration feature. This feature allows you to calibrate a Honeywell Analytics gas detector in about the same time as it takes to complete a “bump” test. The use of automatic bump test and calibration stations can further simplify the tasks, while automatically maintaining records.

**Don't take a chance
with your life.
Verify accuracy frequently!**

Please read also Honeywell Analytics application note: AN20010808 "Use of 'equivalent' calibration gas mixtures". This application note provides procedures to ensure safe calibration of LEL sensors that are subject to silicone poisoning.

Honeywell Analytics website is at:

www.honeywellanalytics.com

Appendix C MultiPro Sensor Information

Part No.	Description	Range	Resolution
54-49-80	LEL Combustible Gas	0 – 100% LEL	1% LEL
54-49-90	O ₂ Oxygen	0 – 30% by Volume	0.1%
54-49-01	CO Carbon Monoxide	0 – 1000 PPM	1 PPM
54-49-02	H ₂ S Hydrogen Sulfide	0 – 200 PPM	1 PPM
54-49-14	Duo-Tox Dual Channel CO/H ₂ S Provides substance specific readouts for CO & H ₂ S	CO: 0 – 1000 PPM H ₂ S: 0 – 200 PPM	1 PPM 1 PPM
54-49-24	Duo-Tox Dual Channel CO/H ₂ S Provides substance specific readouts for CO & H ₂ S Requires firmware version 2.05 or higher	CO: 0 – 1000 PPM H ₂ S: 0 – 200 PPM	1 PPM 1 PPM

Appendix D Toxic Sensor Cross-Sensitivity

The table below provides the cross-sensitivity response of the MultiPro toxic gas sensors to common interference gases. The values are expressed as a percentage of the primary sensitivity, or the reading of the sensor when exposed to 100ppm of the interfering gas at 20°C. These values are approximate. The actual values depend on the age and condition of the sensor. Sensors should always be calibrated to the primary gas type. Cross-sensitive gases should not be used as sensor calibration surrogates without the express written consent of Honeywell Analytics.

SENSOR	CO	H ₂ S	SO ₂	NO	NO ₂	Cl ₂	ClO ₂	H ₂	HCN	HCl	NH ₃	C ₂ H ₄	C ₂ H ₂
Carbon Monoxide (CO)	100	10	5	10	-15	-5	-15	50	15	3	0	75	250
Hydrogen Sulfide (H ₂ S)	0.5	100	20	2	-20	-20	-60	0.2	0	0	0	n/d	n/d

Appendix E Basic Parts List

MultiPro Remote Sampling Accessories

Part No.	Description
54-49-102	Continuous sample pump for MultiPro. Includes 10' of sample tubing and sample probe assembly. UL/CSA-approved version.
54-49-102-5	Continuous sample pump for MultiPro. Includes 10' of sample tubing and sample probe assembly. ATEX-approved version (European).
54-49-104	Sample draw/calibration adapter.
54-49-105	Sample draw kit. Includes adapter, squeeze bulb, 10' of tubing and sample probe assembly.
54-05-A0403	Sample probe assembly. Does not include tubing, squeeze bulb, or sample draw adapter.
54-05-A0405	Sample probe assembly with 11.5-inch stainless-steel probe tube. Does not include tubing, squeeze bulb, or sample draw / calibration adapter.

MultiPro Sensors

Part No.	Description
54-49-80	LEL Combustible gas
54-49-90	O ₂ Oxygen
54-49-01	CO Carbon monoxide
54-49-02	H ₂ S Hydrogen sulfide
54-49-14	Duo-Tox Dual channel CO/H ₂ S Provides substance specific readouts for CO & H ₂ S
54-49-200	Multi Pro sensor exchange set. O ₂ , LEL, Duo-Tox***
54-49-201	Multi Pro sensor exchange set. O ₂ , LEL, CO***
54-49-202	Multi Pro sensor exchange set. O ₂ , LEL, H ₂ S***

***This part number requires return of identical set of expired sensors.

MultiPro Charging & Datalogging Accessories

Part No.	Description
54-49-103-1	Slip-in fast charger (110 VAC) for MultiPro. Includes "wall cube" supply (UL/CSA-Version)
54-49-103-5	Slip-in fast charger (220 VAC) for MultiPro. Includes "wall cube" supply (ATEX-Version)
54-49-103-12	Slip-in fast charger (12 VDC) for MultiPro. Includes "cigarette lighter" style adapter, and vehicle mounting hardware)

54-49-106	MultiPro Alkaline battery pack (UL/CSA-approved version)
54-49-106-5	MultiPro Alkaline battery pack (ATEX-approved version (European))
54-49-107	MultiPro Li-Ion rechargeable battery pack (UL/CSA-Approved version)
54-49-107-5	MultiPro Li-Ion rechargeable battery pack (ATEX-approved version (European))
54-26-0603	MultiPro BioTrak Software Kit. Includes BioTrak software and manual
54-26-0605	Infrared communication device (Serial – IrDA) - <i>Requires one available PC serial port.</i>

Appendix F Honeywell Analytics Standard Gas Detection Warranty

General

Honeywell Analytics, Inc. (hereafter Honeywell Analytics) warrants gas detectors, sensors and accessories manufactured and sold by Honeywell Analytics, to be free from defects in materials and workmanship for the periods listed in the tables below.

Damages to any Honeywell Analytics products that result from abuse, alteration, power fluctuations including surges and lightning strikes, incorrect voltage settings, incorrect batteries, or repair procedures not made in accordance with the Instrument's Reference Manual are not covered by the Honeywell Analytics warranty.

The obligation of Honeywell Analytics under this warranty is limited to the repair or replacement of components deemed by the Honeywell Analytics Instrument Service Department to have been defective under the scope of this standard warranty. To receive consideration for warranty repair or replacement procedures, products must be returned with transportation and shipping charges prepaid to Honeywell Analytics, or to a Honeywell Analytics Authorized Warranty Service Center. It is necessary to obtain a return authorization number from Honeywell Analytics prior to shipment.

THIS WARRANTY IS EXPRESSLY IN LIEU OF ANY AND ALL OTHER WARRANTIES AND REPRESENTATIONS, EXPRESS OR IMPLIED, INCLUDING BUT NOT LIMITED TO, THE WARRANTY OF FITNESS FOR A PARTICULAR PURPOSE. HONEYWELL ANALYTICS WILL NOT BE LIABLE FOR LOSS OR DAMAGE OF ANY KIND CONNECTED TO THE USE OF ITS PRODUCTS OR FAILURE OF ITS PRODUCTS TO FUNCTION OR OPERATE PROPERLY.

Instrument & Accessory Warranty Periods

Product(s)	Warranty Period
PHD6™	2 years from date of purchase
ToxiPro®, MultiPro™	2 years from date of purchase
Battery packs and chargers, sampling pumps and other components, which by their design are consumed or depleted during normal operation, or which may require periodic replacement	One year from the date of purchase

Sensor Warranty Periods

Instrument(s)	Sensor Type(s)	Warranty Period
PHD6™, Cannonball3™, Multi Vision™, MultiPro™, Toxi Vision® ToxiPro®,	O ₂ , LEL**, CO, CO+, H ₂ S & Duo-Tox	2 Years
	All Other Sensors	1 Year
All Others	All Other Sensors	1 Year
	All Sensors	1 Year

** Damage to combustible gas sensors by acute or chronic exposure to known sensor poisons such as volatile lead (aviation gasoline additive), hydride gases such as phosphine, and volatile silicone gases emitted from silicone caulks/sealants, silicone rubber molded products, laboratory glassware greases, spray lubricants, heat transfer fluids, waxes & polishing compounds (neat or spray aerosols), mold release agents for plastics injection molding operations, waterproofing formulations, vinyl & leather preservatives, and hand lotions which may contain ingredients listed as cyclomethicone, dimethicone and polymethicone (at the discretion of Honeywell Analytics Service department) void Honeywell Analytics Standard Warranty as it applies to the replacement of combustible gas sensors.